

EOM-G103-PHR-PTP Series

IEC 62439-3 3-port full Gigabit embedded managed redundancy modules

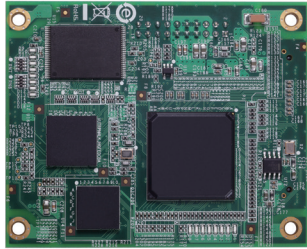

- > IEC 62439-3 Clause 4 (PRP) and Clause 5 (HSR) compliant
- > 3 SGMII pinouts reserved for PRP/HSR (LAN A/LAN B/Inter Link) and an extra 1 SGMII reserved for Ethernet console connection



Introduction

The EOM-G103-PHR-PTP series full Gigabit managed redundancy modules are designed for device manufacturers who would like to embed and integrate the advanced IEC 62439-3 supported modules with minimum effort into their products to enhance performance and reliability of certain mission-critical applications.

IEC 62439-3 Clause 4 (PRP) and IEC 62439-3 Clause 5 (HSR) are the newest standardized redundancy protocols for industrial automation networks where zero recovery time is needed. PRP and HSR are suitable for electrical substation automation and other mission-critical applications that cannot tolerate any system downtime.

The EOM-G103-PHR-PTP series modules are compliant with the latest IEC 62439-3 standards and provide an easy and cost-effective integrated solution for adding a redundancy module to a non-IEC 62439-3 supported product. The modules support two IEC 62439-3 Ethernet ports for constructing PRP or HSR networks: SGMII (MAC mode) / SERDES (1000BaseX). It also includes one standard Ethernet port SGMII (MAC mode) / SERDES (1000BaseX) for connecting with standard IEEE 802.3 Ethernet devices. Additionally, the EOM-G103-PHR-PTP series provides an extra SGMII (MAC mode) / SERDES (1000BaseX) for building up a local access Ethernet console port to easily maintain, control, and manage devices at the local site.

General Features and Benefits

- PRP (Parallel Redundancy Protocol): Transmit or receive two independent active paths to/from different LANs simultaneously in a zero recovery time network.
- HSR (High-availability Seamless Redundancy): Every frame is duplicated and then transmitted in both directions of the HSR ring to deliver zero switchover time.
- Hardware-based IEEE 1588v2 PTP (Precision Time Protocol) end-to-end one-step transparent clock for precise time synchronization of networks.
- Configurable via CLI.

Specifications

Technology

Standards:

IEEE 802.3 for 10BaseT
 IEEE 802.3u for 100BaseT(X) and 100BaseFX
 IEEE 802.3ab for 1000BaseT(X)
 IEEE 802.3z for 1000BaseX

Software Features

Management: IPv4 / IPv6, SNMP v1/v2c/v3, Telnet/SSH, LLDP, Flow Control, Back Pressure Flow Control, Port Mirror, Fiber Check, Syslog, RMON

Filter: Multicast Filter Behavior

Redundancy Protocols: PRP/HSR, RSTP Transparent

Security: RADIUS, TACACS+, Trusted Access Control, Authentication Certificate (SSL Certificate, SSH Key Regenerate)

Time Management: SNTP, NTP Server/Client, IEEE 1588v2 PTP

Industrial Protocols: Modbus/TCP

Power Substation: MMS

Interface

Ethernet Ports: 3, SGMII (MAC mode) / SERDES (1000BaseX) (PRP/HSR LAN A/LAN B/INTERLINK)

Connectors: 1 connector with 2 x 40 pins, and 1 connector with 2 x 10 pins

Console Port: Ethernet console (SGMII (MAC mode) / SERDES (1000BaseX))

GPIO: 3 programmable I/O pins

Power Requirements

Input Current: Max. 1.625 W @ 3.3 V

Physical Characteristics

Dimensions: 80 x 1.6 x 65 mm (3.15 x 0.06 x 2.56 in)

Weight: 28.6 g (0.06 lb)

Environmental Limits

Operating Temperature: -40 to 60°C (-40 to 140°F)

Note: Products with a higher operating temperature are available by special request.

Storage Temperature: -40 to 85°C (-40 to 185°F)

Ambient Relative Humidity: 5 to 95% (non-condensing)

Standards and Certifications

EMI: FCC Part 15 Subpart B Class A, EN 55032 Class A, CE Class A
 Note: Please check Moxa's website for the most up-to-date certification status.

Warranty

Warranty Period: 5 years
 Details: See www.moxa.com/warranty

Dimensions

Unit: mm (inch)

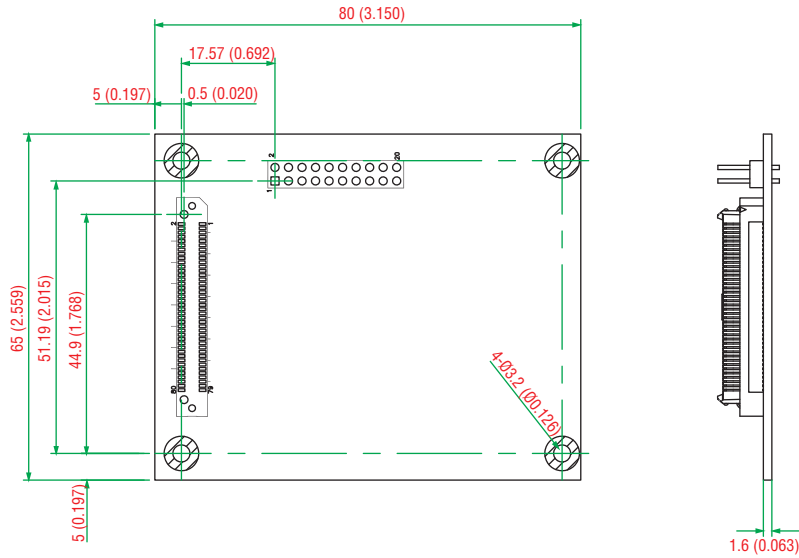

Pin Assignment

Pin assignment table for JP1 (2 x 40)

Pin	Signal	Pin	Signal	Pin	Signal	Pin	Signal
1	GND	2	GND	41	PRP_LED	42	DI
3	DTR(UART)	4	DCD(UART)	43	FAULT_LED	44	Reserved
5	RTS(UART)	6	DSR(UART)	45	STAT_R_LED	46	Reserved
7	TXD(UART)	8	CTS(UART)	47	STAT_G_LED	48	Reserved
9	GND	10	RXD(UART)	49	TX_DIS_G3(SFP)	50	GND
11	GXB_RX_P_0(SGMII)	12	GND	51	PRESENT_G3(SFP)	52	Reserved
13	GXB_RX_N_0(SGMII)	14	GXB_TX_P0(SGMII)	53	LOS_G3(SFP)	54	Reserved
15	GND	16	GXB_TX_N0(SGMII)	55	TX_DIS_G2(SFP)	56	GND
17	GXB_RX_P_1(SGMII)	18	GND	57	PRESENT_G2(SFP)	58	SDA-(I2C)
19	GXB_RX_N_1(SGMII)	20	GXB_TX_P1(SGMII)	59	LOS_G2(SFP)	60	SCK-(I2C)
21	GND	22	GXB_TX_N1(SGMII)	61	TX_DIS_G1(SFP)	62	GND
23	GXB_RX_P_2(SGMII)	24	GND	63	PRESENT_G1(SFP)	64	MDIO-PHY(SMI)
25	GXB_RX_N_2(SGMII)	26	GXB_TX_P2(SGMII)	65	LOS_G1(SFP)	66	MDC-PHY(SMI)
27	GND	28	GXB_TX_N2(SGMII)	67	TX_DIS_G0(SFP)	68	GND
29	GXB_RX_P_3(SGMII)	30	GND	69	PRESENT_G0(SFP)	70	Reserved
31	GXB_RX_N_3(SGMII)	32	GXB_TX_P3(SGMII)	71	LOS_G0(SFP)	72	Reserved
33	GND	34	GXB_TX_N3(SGMII)	73	Reserved	74	GND
35	COUP_LED	36	GND	75	Reserved	76	USB-HOST-DP
37	QB_LED	38	DO(1)	77	Reserved	78	USB-HOST-DM
39	HSR_LED	40	DO(0)	79	Reserved	80	GND

Pin assignment table for JP2 (2 x 10)

Pin	Signal	Pin	Signal
1	Reserved	2	Reserved
3	Reserved	4	Reserved
5	Reserved	6	Reserved
7	3.3V	8	3.3V
9	3.3V	10	3.3V
11	3.3V	12	GND
13	GND	14	GND
15	GND	16	GND
17	Reset_PHY	18	Reset
19	Reserved	20	Reset to Default

: Starter Kit

The EOM Starter Kit includes an evaluation board, power adapter, software CD, and USB-IF certified cable to allow quick and easy evaluation of all embedded redundancy module functions. The

evaluation board is equipped with 3 10/100/1000BaseT(X) and 100/1000BaseSFP slot combo ports.

: Ordering Information

Available Modules

EOM-G103-PHR-PTP: IEC 62439-3 managed redundancy module with 3 SGMII pinouts reserved for 2 IEC 62439-3 ports and 1 standard Ethernet port, with an extra 1 SGMII reserved for Ethernet console connection, 3.3 V operating power input voltage, -40 to 85°C operating temperature

Optional Starter Kits (must be purchased separately)

EOM-G103-PHR-PTP-ST: Includes an EOM-G103-PHR-PTP managed redundancy module and an evaluation board with 3 10/100/1000BaseT(X) and 100/1000BaseSFP slot combo ports for testing and application development

Package Checklist (modules)

- EOM-G103-PHR-PTP module
- Developer's guide

Package Checklist (starter kits)

- EOM-G103-PHR-PTP module
- EOM-G103-PHR-PTP evaluation board
- USB Cable: CBL-USBA/B-100
- Universal power adapter
- 2 power cords (US or Euro plug)
- Developer's guide