

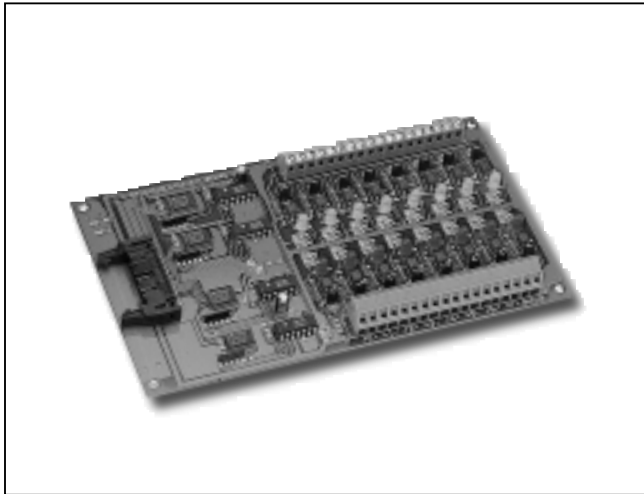

DB-16P

16-Channel Opto-Isolated Digital Input Board



Functional Description

The DB-16P is a 16 channel isolated digital input daughterboard for A-82X board. The optically isolated inputs of the DB-16P consists of a bi-directional OPTO-coupler with a resistor for current sensing. You can use the DB-16P to sense DC signal from TTL levels up to 24V You can also use DB-16P to sense a wide range of AC signals. You can use the board to isolated the computer from large common-mode voltages, ground loops and voltage spikes that often occur in industrial environments.

Features

- 16 optically isolated digital input channels
- Connects directly to A-82X board, ISO-730, DIO-64, PCI-TMC12, PCI-180X, A-626, A-628, ISO-DA8/16
- AC/DC signal Input
- AC signal input with filter
- Input buffer with voltage compactors

Applications

- Isolated digital input sensing
- Energy management
- Test Automation
- Process Control

Specifications

- I/O connector Electrical Specifications
 - Configuration : 16 optically isolated digital input channels
 - Compatibility : TTL compatible
- Digital Input
 - Number of channels : 16 channels, each with it's own ground reference isolated from other channels
 - Maximum input voltage :24 VDC or 24 VAC
 - Power Consumption : 12V /0.53V ; 5V / 0.2A
 - Digital Logic Level :

Level	Minimum	Maximum
Input low voltage (DC or peak AC)	0	±1V
Input high voltage DC/1kHz AC	±2.8VDC 4Vrms	±24VDC 24VAC

- Input impedance: 1.2k
- Source Current
 - 5V inputs: 4 mA/channel minimum
 - 24V inputs: 20 mA/channel minimum
- Response Time: 20µs without filter / 2.2ms with filter
- Power Supplies +5V@224mA/ maximum
- Dimension :205mm x 114 mm
- Operating Temperature: 0 -50°C
- Storage Temperature: -20-70°C
- Humidity: 5% to 90 % non-condensing

Order Description

- DB-16P: 16 channel Isolation Board with 20-PIN flat-cable

Isolation Digital Input With AC Filter Circuit

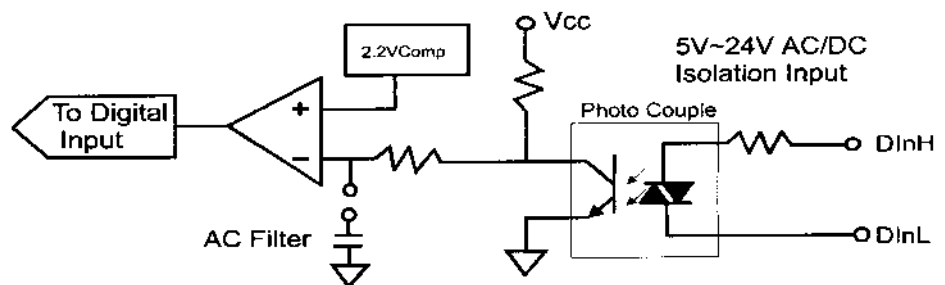

Distribué par :



2 rue René Laennec 51500 Taissy France Email : hvssystem@hvssystem.com
 Fax: 03 26 85 19 08, Tel : 03 26 82 49 29 Site web : www.hvssystem.com



DB-16R

16-Channel Relay Output Board

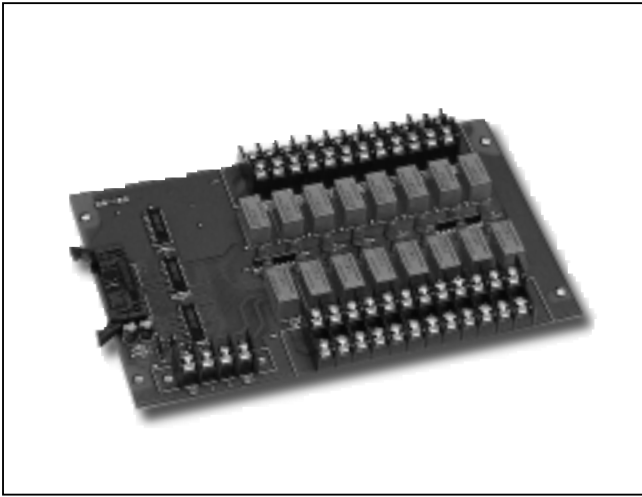

Functional Description

The DB-16R 16 channel Relay Output Board consists of 16 form c relays for efficient switch of load by programmed control. The DB-16R can be used by A-82x board or any other compatible board. The relay are energized by apply 5 volt signal to the appropriate relay channel on the 20-pin flat cable connector. Sixteen enunciator LEDs, one for each relay, light when their associated relay is activated. To avoid overloading your PC's power supply, this board provides a screw terminal for power supply .

Features

- Form C relays
- Accept 20-pin connector to control 16 form c relays, for use with A-82X, DIO-64, PCI-180X, PCI-1202, PCI-1002, A-626/628, digital output port or any compatible digital output port
- Each LED lights when corresponding relay is activated
- Screw terminals for field wiring

Applications

- On/off control
- Energy management
- Test Automation
- Process control

Specifications

- Form C Relay
 - Type: SPDT (form C)
 - Nominal load: 0.5 A/120 VAC, 1A/24 VDC
 - Max. Switching power: 60VA, 24W
 - Max. Switching Voltage: 120VAC, 60VDC
 - Max. Switching Current: 1A
 - Life Expectancy: Mechanical (2×10^7), Electrical (2×10^5)
 - Release Time Value: Operate (6 ms)
 - Control Logic: Input TTL high (+5V), relay on
- Power Consumption: +12V @528mA max.
+5V @150mA max.
- Dimensions: 205mm x 114mm
- Operating Temperature: 0 -50°C
- Storage Temperature: -20~70°C
- Humidity: 5% to 90%

Order Description

- DB-16R: 16 channel relay Board with 20-Pin flat cable

Daughter Board

From C Relay

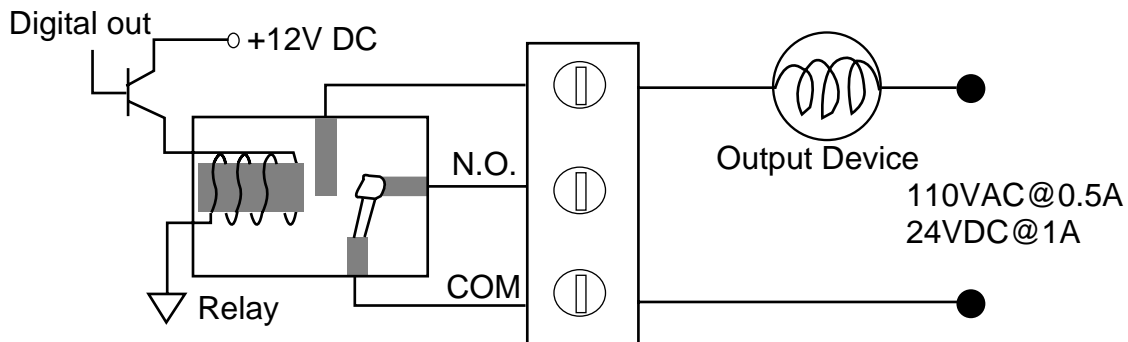



DB-24R / DB-24RD

24-Channel Relay Output Board

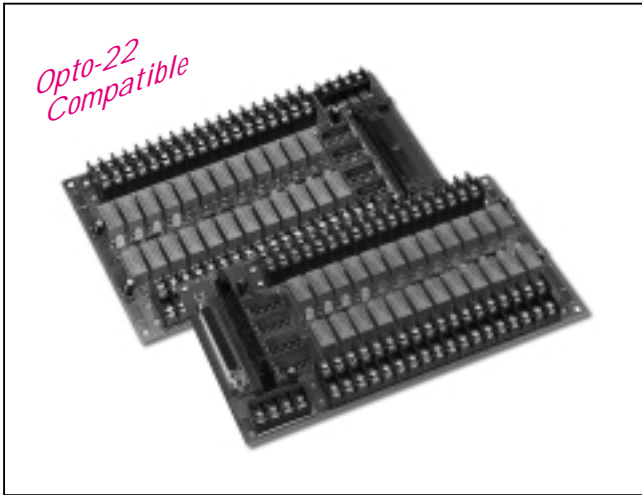

Functional Description

The DB-24R consists of 24 form C, electromechanical relays for efficient switching of load by programmed control. The contact of each relay can control a 0.5 A/110 V load or 1A/24VDC. The relay is energized by applying a 5 voltage signal to the appropriate relay channel on the 50-pin Opto-22 compatible connector or D-Sub 37 connector. Twenty-four annunciator LEDs, one for each relay, light when their associated relay is activated. To avoid overloading your PC's power supply, this board needs a +12VDC or +24VDC external power supply.

Features

- 24 Form C Relays (SPDT)
- OPTO-22 Compatible Connector
- Connects directly to DIO-24, DIO-48, DIO-144 OPTO-22 compatible board
- Switch up to 0.5A at 120 VAC
- Switch up to 1A at 24VDC

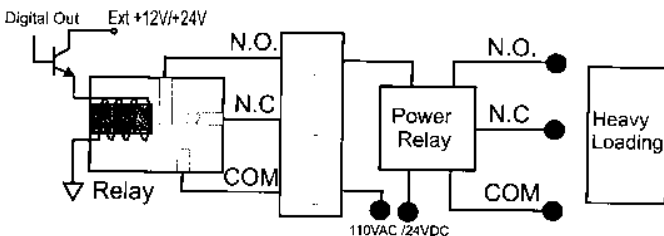

- On board relay driver circuits
- LED's indicates relay status
- Screw terminals for easy field wiring

Applications

- On/off control
- Energy management
- Test automation
- Process control

Specifications

- Form C Relay
 - Type: 1 form C
 - Nominal load: 0.5 A /120 VAC, 1A/24 VDC
 - Max. Switching power: 60VA, 24W
 - Max. Switching Voltage: 120VAC, 60VDC
 - Max. Switching Current: 1A
 - Life Expectancy: Mechanical (2×10^7), Electrical (2×10^5)
 - Time Value: Operate (6 ms)
 - Control Logic: Input TTL high (+5V) , relay on
 - Power Consumption: +12V @0.3A max
 - +5V @0.18A max

- Dimensions: 225mm x 132mm
- Operating Temperature: 0 -50°C
- Storage Temperature: -20-70°C
- Humidity: 5% to 90 %

Order Description

- DB-24R/12: 24 channel OPTO-22 Relay (12V) Board
- DB-24R/12/DIN: DB-24R/12 with DIN-Rail mounting kit
- DB-24R/24: 24 channel OPTO-22 Relay (24V) Board
- DB-24R/24/DIN: DB-24R/24 with DIN-Rail mounting kit
- DB-24RD/12: 24 channel OPTO-22 Relay Board (12V) with D-Sub 37 connector
- DB-24RD/12/DIN: DB-24RD/12 with DIN-Rail mounting kit
- DB-24RD/24: 24 channel OPTO-22 Relay Board (24V) with D-Sub 37 connector
- DB-24RD/24/DIN: DB-24RD/24 with DIN-Rail mounting kit



DB-24PR / DB-24PRD

24-Channel Power Relay Output Board

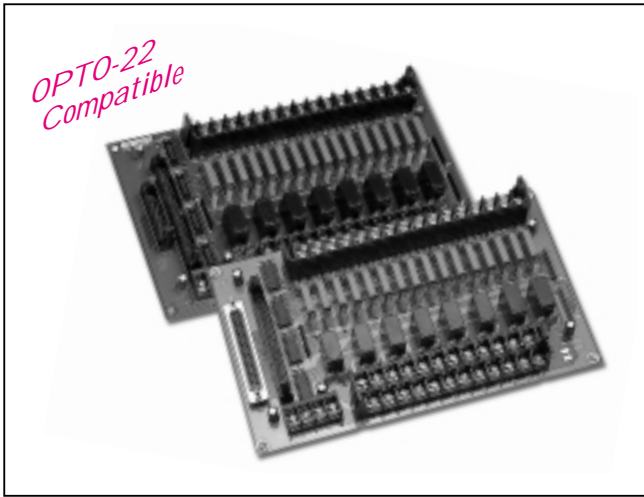

Functional Description

The DB-24PR/DB-24PRD 24-Channel power relay output board consists of 8 form C and 16 form A electromechanical relays for efficient switching of load by programmed control. The contact of each relay can control a 5 A load at 250VAC/30VDC. The relay is energized by applying 50-pin OPTO-22 compatible connector, 37-pin D-sub connector or 20-pin flat cable connector. Twenty-four enunciator LEDs, one for each relay, light when their associated relay is activated. To avoid overlading your PC's power supply, this board needs a +12VDC or +24VDC external power supply.

Features

- 8 Form C Relays (SPDT) and 16 Form A Relay
- DB-24PR: Accept 50-pin connector to control 8 form C and 16 form A relay or accept 20-pin connector to control 8 form C and 8 form A relay
- DB-24PRD: Accept 37-pin connector and 50-pin connector to control 8 form C and 16 form A relay
- Switch up to 5A at 250A VAC/5A at 30VDC
- LEDs indicated relay status
- Designed varistor to protect each channel's high voltage spike

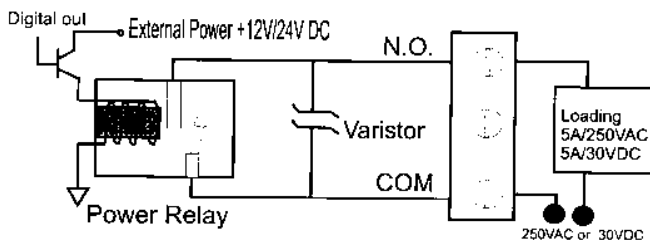

- Screw terminals for easy field wiring
- 50-Pin header Connects directly to DIO-24, DIO-48, DIO-144, PCI-D144, or other OPTO-22 compatible board
- 20-Pin header connects directly to A-82x, A-626, A-628, DIO-64, PCI-1800, PCI-1802, PCI-1202, PCI-1602, PCI-1002, PCI-DA16, PCI-TMC12, ISO-DA16/8
- D-sub connector connect directly to PIO-D144, PIO-D96, PIO-D56, PIO-D48, PIO-D24

Applications

- On/off control
- Energy management
- Test Automation
- Process control

Specifications

- Relay
 - Nominal load: 5 A/250 VAC, 5A/30 VDC
 - Max. Switching power: 0.1HP
 - Max. Switching Voltage: 270VAC, 150VDC
 - Max. Switching Current: 5A
 - Life Expectancy: Mechanical (2×10^7), Electrical (3×10^4)
 - Time Value: Operate (10 ms)
 - Control Logic: Input TTL high (+5V), relay on
- Power Consumption: 24V @0.8A max.; 5V @0.2A max.
- Dimensions: 130mm x 210mm
- Operating Temperature: 0 -50°C
- Storage Temperature: -20~70°C
- Humidity: 5% to 90%

Order Description

- DB-24PR/12: 24 channel OPTO-22 Relay (12V) Board
- DB-24PR/12/DIN: DB-24PR/12 with DIN-Rail mounting kit
- DB-24PR/24: 24 channel OPTO-22 Relay (24V) Board
- DB-24PR/24/DIN: DB-24PR/24 with DIN-Rail mounting kit
- DB-24PRD/12: 24 channel OPTO-22 Relay Board (12V)with D-Sub 37 connector
- DB-24PRD/12/DIN: DB-24PRD/12 with DIN-Rail mounting kit
- DB-24PRD/24: 24 channel OPTO-22 Relay Board (24V) with D-Sub 37 connector
- DB-24PRD/24/DIN: DB-24PRD/24 with DIN-Rail mounting kit



DP-24P / DP-24PD

24-Channel Opto-Isolated Input Board

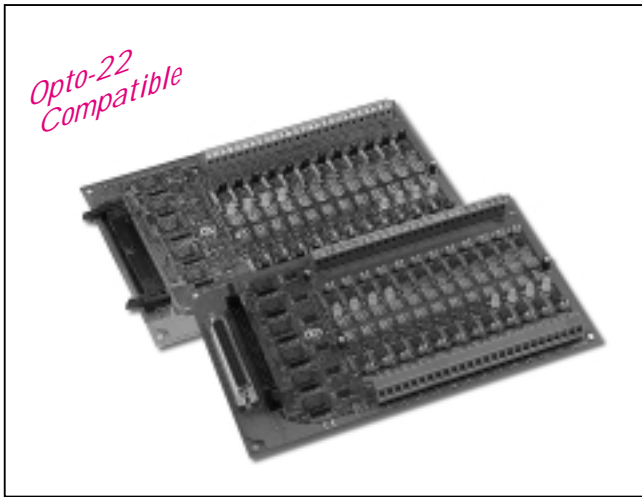

Daughter Board

Functional Description

The DB-24P/DB-24PD is a 24-channel isolated digital input daughter board for DIO-24, DIO-48, DIO-144, PCI-D144 OPTO-22 compatible digital input board. The 24-channel inputs of the DB-24PD consist of a bi-directional opto-coupler with a resistor for current sensing. You can use the DB-24PD to sense DC signal from TTL levels up to 24V. You can also use DB-24PD to sense a wide range of AC signals. The DB-24PD registers a constant logic high, if the frequency of the input AC signal is greater or equal to 1 kHz, and if the voltage of the AC signal is at least 4Vrms. If you are using AC input signal, you must short the AC filter Jumper. You can use the board to isolate the computer from large common-mode voltages, ground loops, and voltage spikes that often occur in industrial environments.

Features

- Optically isolated digital input channels
- Connects directly to DIO-24, DIO-48, DIO-144, PCI-D144 or other OPTO-22 compatible digital input card
- AC/DC Signal Input
- AC Signal Input with filter
- Input buffer with voltage comparators

Applications

- Isolated digital input sensing
- Testing Automation

Specifications

- I/O connector Electrical Specifications
- Configuration: 24 optically isolated digital input channels
- Compatibility: TTL compatible
- Digital Input
- Number of channels: 24, each with its own ground reference isolated from other channels
- Maximum input voltage: 24 VDC or 24 VAC
- Digital Logic Level

Level	Minimum	Maximum
Input low voltage (DC or peak AC)	0	±1V
Input high voltage DC/1kHz AC	±2.8VDC 4Vrms	±24VDC 24VAC

Input impedance : 1.2k

Source Current

5V inputs: 4mA/channel minimum

24V inputs: 20mA/channel minimum

Response Time: 20µs without filter/2.2ms with filter

- Power Supplies: +5v: 336mA /maximum
- Board Dimensions: 220 mm x 132 mm
- Operating Temperature: 0 -50°C
- Storage Temperature: -20-70°C
- Humidity: 5% to 90 %

Order Description

- DB-24P: 24 channel Isolated Input Board with 50-pin flat cable
- DB-24P/DIN: DB-24P with DIN-Rail mounting kit
- DB-24PD: 24 channel Isolated Input Board with D-Sub 37 connector
- DB-24PD/DIN: DB-24PD with DIN-Rail mounting kit

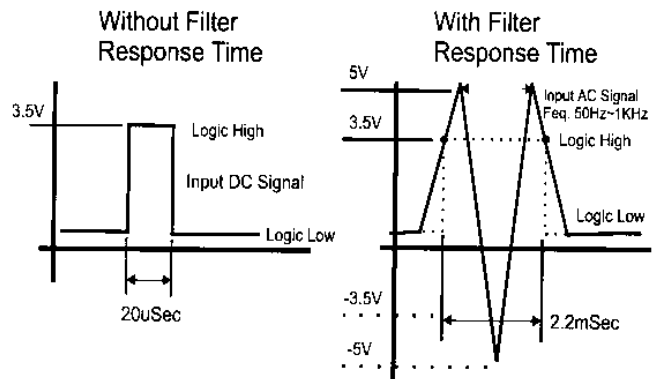



DB-24POR

24-Channel Photo Mos Output Board

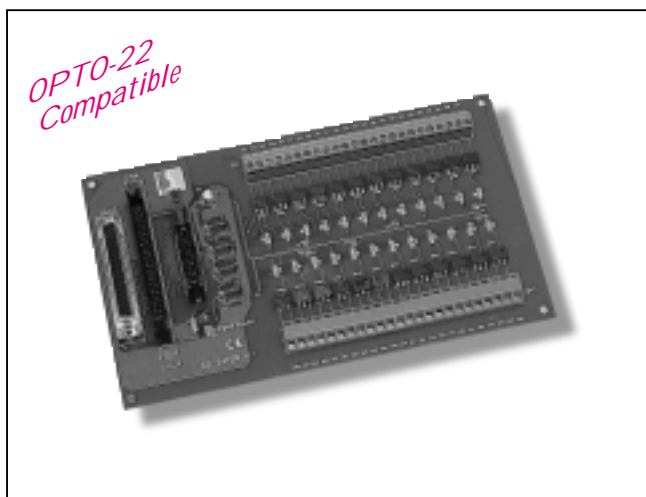

Functional Description

The DB-24POR includes 24 normally open, Form A, Photo Mos Relays. The board interface to field logic signals, eliminating ground-loop problems and isolating the host computer from damaging voltages. The user can use the DB-24POR to switch load, up to 350VAC and up to 0.13 A. The relay is energized by applying a 5 volt signal to the appropriate relay channel on the 50-pin OPTO-22 compatible connector or 37-pin D-Sub connector. Twenty-four unicolor LEDs, one for each relay, light when their associated relay is activated. Because there is a D-sub 37-pin connector on the board, the user may use it to interface to any TTL output board. In other words, the user may use it as a general purpose Photo Mos Relay Output Board.

Features

- 24 optically isolated digital output channels
- 24 Form A Photo Mos Relays
- Switch up to max. 0.13A at max. 350VAC
- 5VDC logic levels
- 5,000V optical isolation
- LED indicate relay status

- Screw terminal for easy field wiring
- Build in fuses and diodes to protect from wrong connection of external power supply.
- 50-Pin header connects directly to DIO-24, DIO-48, DIO-144, PIO-D144 OPTO-22 compatible board or any 722,724 series board
- D-Sub 37 pin connector connects directly to PCI-D144 board or another OPTO-22 board with ADP-37 adapter

Applications

- On/off control
- Energy management
- IC Factory Automation
- Test Automation
- Process Control

Specifications

- PHOTO MOS RELAY
 - Turn on time : $T_{on} = 0.7\text{ms}$ (Typical)
 - Turn off time : $T_{off} = 0.05\text{ms}$ (Typical)
 - Output : on resistance = 23Ω (typical)
 - Load voltage : 350V (Peak AC)
 - Continuous load current : 0.13A (Peak AC)
 - Power dissipation : 500mW
 - Input / Output isolation : 5000 V(AC)
 - Power Consumption : 5V @ 0.3A max.
 - Dimensions : 130mm x 220mm
 - Operating Temperature : 0 -60°C
 - Storage Temperature : -20-70°C
 - Humidity : 5% to 90 % , noncondensing

Order Description

- DB-24POR : 24 channel OPTO-22 Photo Mos Relay Board with 1.5 meter 50-pin flat-cable
- DB-24POR/D: 24 channel OPTO-22 Photo Mos Relay Board with 1.5 meter 37-pin D-sub cable
- DB-24POR/DIN : DB-24POR with DIN-Rail mounting kit
- DB-24POR/D/DIN: DB-24POR/D with DIN-Rail mounting kit



DB-16P8R

16-Channel Opto-isolated Digital Input & 8-Channel Relay Output Board

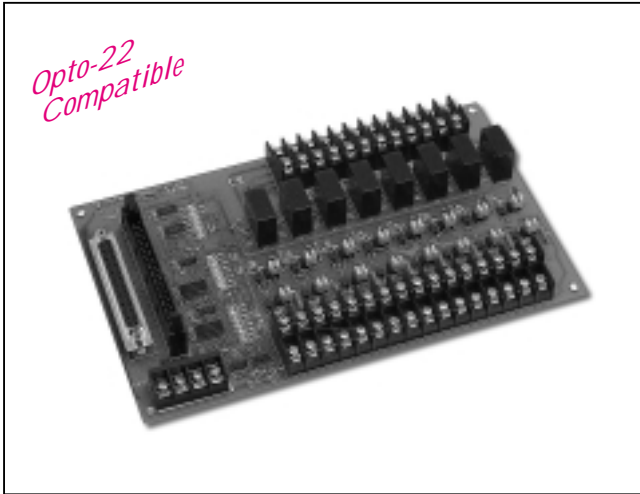

Functional Description

The DB-16P8R consists of 8 form C relay and 16 channel isolated digital input, Each digital input accepts from 3VDC to 24VDC. The contact of each relay can control a 5 A load at 250VAC/30VDC, The relay is energized by applying a 5 voltage signal to the appropriate relay channel on the 50-pin OPTO-22 compatible connector or DB-37 D-sub connector. Both isolated inputs and relay outputs are equipped with LEDs that light up when their associated relay is activated or input signal are at "high" state. To avoid overloading your PC's power supply, this board needs a +24VDC external power supply.

Features

- 16 opto-isolated digital inputs
- 8 Form C Relays (SPDT)
- Accept 50-pin connector or D-sub 37 connector to control 8 Form C relays and 16 opto-isolated digital inputs
- Switch up to 5A at 250VAC/5A at 30VDC
- LEDs indicated relay status
- Optional Varistor to protect each channel's high voltage spike
- Screw terminals for easy field wiring
- 50-Pin header Connects directly to DIO-24, DIO-48, DIO-144, PIO-D144, OPTO-22 compatible board or any 722,724 series board
- Jumper selectable for voltage input or dry contact input mode
- 3750V isolation

Applications

- On/off control
- Energy management
- Isolated digital input sensing
- Test Automation
- Process Control

Specifications

Relay

Nominal load: 5A/250VAC, 5A/30VDC

Max. Switching power: 0.1HP

Max. Switching Voltage: 270VAC, 150VDC

Max. Switching Current: 5A

Life Expectancy: Mechanical (2×10^7)

Electrical (3×10^4)

Time Value: Operate (10 ms)

Control Logic: Input TTL high A(+5V), relay on

Isolated Digital Input

Type: isolated current input

Isolation Voltage: 3750V

Input Voltage: 3.5V to 30V

Input impedance: 3K

Response time: 10KHz Max

Dry Contact Input

Logic high: Input Close

Logic Low: Input Open

Power Consumption: 24V@0.3A max.

5V@0.1A max

Dimension: 130mm x 210mm

Operating Temperature: 0~60°C

Storage Temperature: -20~70°C

Humidity: 5% to 90% noncondensing

Order Description

- DB-16P8R: 16 Opto-isolated Digital Input & 8-Channel relay output Board with 50-pin flat cable(+24V version)
- DB-16P8R/DIN: DB-16P8R with DIN-Rail mounting kit
- DB-16P8R/D: 16 Opto-isolated Input & 8 relay output Board with 1.5 meter 37-pin D-Sub cable (+24V version)
- DB-16P8R/D/DIN: DB-16P8R/D with DIN-Rail mounting kit



DB-24C

24-Channel Open-Collector Output Board

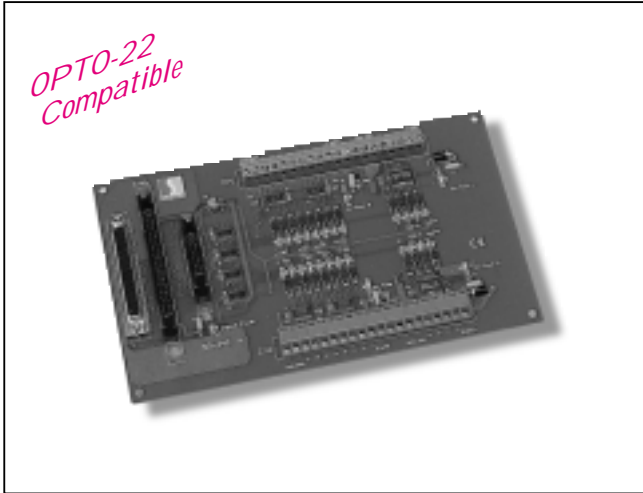

Functional Description

The DB-24C has 24 Channels of optically isolated digital outputs, arranged into four isolated banks. Each digital output offers a darlington transistor and integral suppression diode for inductive load. The board interface to field logic signals, eliminating ground-loop problems and isolating the host computer from damaging voltages. The DB-24C has one 37-pin D-Sub connector, one 50-pin OPTO-22 compatible male header and one 20-pin male header. . The transistor is energized by applying a 5 volt signal to the appropriate input channel on the 50-pin OPTO-22 compatible connector or 20-pin flat cable connector or 37-pin D-Sub connector. Twenty-four enunciator LEDs, one for each transistor, light when their associated transistor is activated . Because there is a D-sub 37-pin connector on the board, the user may use it to interface to any TTL output board. In other words, the user may use it as a general purpose Open-Collector Output Board.

Features

- Group A (low nibble) and Group B (high nibble) has 4-channel high current open-collector output each. The max. load is 600 mA per channel.
- Group A (high nibble), Group B (low nibble), C (byte) and Group D has 8-channel open-collector output each. The maxi. load is 100 mA per channel.

- Accept 20-pin connector to control 8 high current output channel and 8 low current output channel.
- 3750V optical isolation
- 5VDC logical levels

Applications

- LEDs indicate the status of transistor
- Screw terminals for easy field wiring
- 50-Pin header connects directly to DIO-24, DIO-48, DIO-144, PCI-D144 OPTO-22 compatible board or any 722, 724 series board
- 20-Pin header connects directly to A-82X, A-626, A-628, DIO-64, PCI-1002, PCI-1202, PCI-180X, PCI-1602, PCI-DA16
- D-Sub 37 pin connector connects directly to PIO-D144 board or another OPTO-22 board with ADP-37 adaptor

Specifications

- The maximum loading current of each high current output channel : 600mA
The maximum loading current of each low current output channel : 100mA
Power Consumption : 5V @ 0.4A max.
Dimension : 130mm x 220mm
Operating Temperature : 0 -60°C
Storage Temperature : -20-70°C
Humidity : 5% to 90 % noncondensing

Order Description

- DB-24C: 24 channel OPTO-22 Open-Collector output Board with 1.5 meter 50-PIN Flat-Cable
- DB-24C/DIN: DB-24C with DIN-Rail mounting kit
- DB-24C/D: 24 channel OPTO-22 Open-Collector Output Board with 1.5 meter 37 pin D-Sub cable Daughter Board
- DB-24C/D/DIN: DB-24C/D with DIN-Rail mounting kit

	Low nibble	High nibble
Group A	600mA	100mA
Group B	100mA	600mA
Group C	100mA	100mA

Daughter Board



DB-24SSR

24-Channel Solid State Relay Output Board

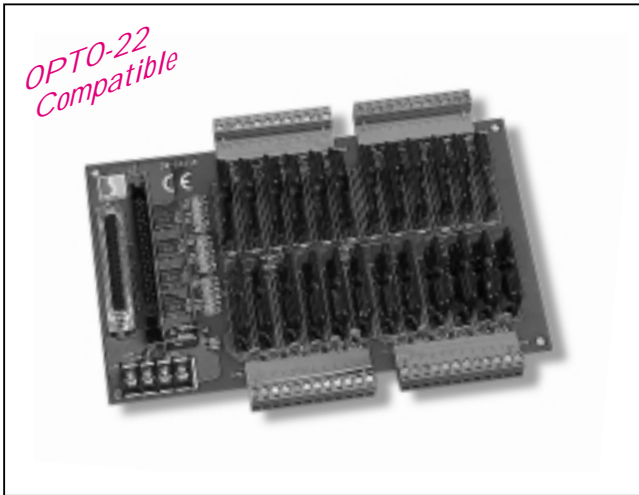

Functional Description

The DB-24SSR includes 24 normally open, or Form A, solid-state relays. The board interface to field logic signals, eliminating ground-loop problems and isolating the host computer from damaging voltages. The user can use the DB-24SSR to switch high voltage load, up to 240VAC and up to 4 A. The relay is energized by applying a 5 volt signal to the appropriate relay channel on the 50-pin OPTO-22 compatible connector or 37-pin D-Sub connector. Twenty-four enunicator LEDs, one for each relay, light when their associated relay is activated. Because there is a D-sub 37-pin connector on the board, the user may use it to interface to any TTL output board. In other words, the user may use it as a general purpose Solid State Relay Output Board.

Features

- 24 optically isolated digital output channels
- 24 Form A solid-state relays
- Switch up to 4A at 250VAC
- 5VDC logic levels
- 2,500V optical isolation
- LEDs indicate relay status
- Screw terminal for easy field wiring
- Can choose plug-in screw-terminal blocks, ensuring simple installation, modification and maintenance

- 50-Pin header connects directly to DIO-24,DIO-48,DIO-144,PIO-D144 OPTO-22 compatible board or any 722,724 series board
- D-Sub 37 pin connector connects directly to PCI-D144 board or another OPTO-22 board with ADP-37 adapter

Applications

- On/off control
- Energy management
- Test Automation
- Process Control

Specifications

- Solid State Relay
- Load Voltage : 50-250VAC
- Repetitive peak OFF voltage : 600 V
- Surge current : 50 A
- Maxi. Load current : 4 A
- Maxi. "OFF-state" leakage current : 50 mA
- Operate time, max. : 1/2 cycle of voltage sine wave
1 ms (Zero-cross)
Power Consumption :5V @ 0.4A max.
Dimension :130mmx220mm
Operating Temperature : 0 -60°C
Storage Temperature : -20-70°C
Humidity : 5% to 90 % noncondensing

Order Description

- DB-24SSR: 24 channel OPTO-22 Solid State Relay Output Board with 1.5 meter Flat Cable
- DB-24SSR/DIN: DB-24SSR with DIN-Rail mounting kit
- DB-24SSR/D: 24 channel OPTO-22 Solid State Relay Output Board with 1.5 meter 37- pin D-Sub Cable
- DB-24SSR/D/DIN: DB-24SSR/D with DIN-Rail mounting kit
- DB-24SSR/D/P: 24 channel OPTO-22 Solid State Board Output Board with Plug-in terminal & 1.5 meter 37- pin D-Sub Cable
- DB-24SSR/D/P/DIN: DB-24SSR/D/P with DIN-Rail mounting kit



DB-889D

16 Channel Analog Multiplexer Board

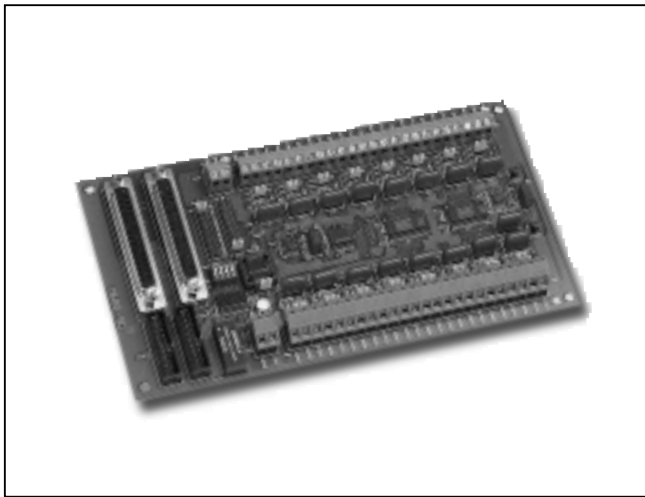

Functional Description

The DB-889D is an expansion multiplexer/ amplifier board for use with A-82X and PCI-1800 series. Each 889D multiplexes 16 differential analog input channels into one analog input of the DAS board. It provides software programmable gains of 0.5, 1, 5, 10, 50, 100, 500 and 1000. Thermocouple measurement are handled easily with 889D. The board includes cold-junction sensing and compensation circuitry that provides a scaling of 24.4mV/°C. Biasing resistors are included for open thermocouple detection. The 889D can be cascaded to a total of 128 channels of voltage measurements or 112 channel of thermocouple measurement.

Features

- Connects directly to A-82X, PCI-1800 series DAS board
- Cold-junction compensation for thermocouples, thermocouple open detection
- Input filtering
- Software-programmable Instrumentation amplifier gain of 0.5, 1, 5, 10, 50, 100, 500 and 1000
- Daisy chain to ten DB-889D

Applications

- Energy management
- Signal conditioning
- Analog multiplexer

Specifications

- Accepts Thermocouple type: J, K, T, E, S, R, B
- Cold-Junction Compensation: +24.4 mV/°C (.1°C/bit), 0.0V at 0.0°C

Gain	Common Mode Rejection	Nonlinearity % of FSR	Settling Time
0.5	99dB	±0.0004	23us
1	99dB	±0.0004	23us
5	114dB	±0.0004	28us
10	114dB	±0.0004	28us
50	123dB	±0.0004	140us
100	123dB	±0.0004	140us
500	123dB	±0.0008	1300us
1000	123dB	±0.0008	1300us

Overvoltage Protection: +/- 30V Continuous

Common mode voltage: ±10V max

Analog output voltage: ±10V

Power requirement: +5V@120mA

Dimensions: 114 mm x 204 mm

Operating temperature: 0 -50°C

Storage temperature: -20°C, -70°C

Humidity: 5% to 90 %

Order Description

- DB-889D: 16 Channel Multiplexer and Signal Conditioning Board With 37-PIN Cable & 20-Pin Flat Cable

Block Diagram

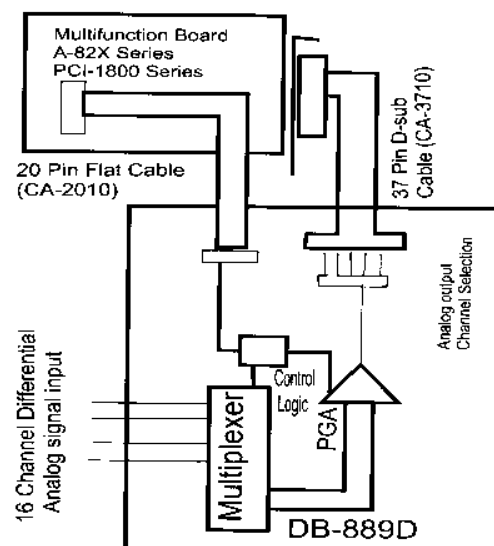

Daughter Board



Screw Terminal Board

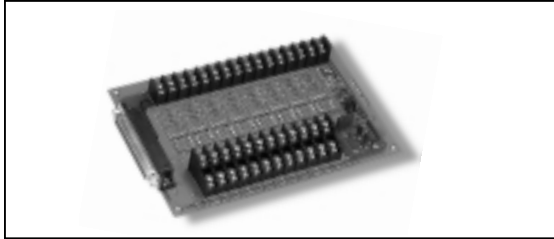

DB-8225 Screw Terminal Board With CJC

- Screw terminal board using 37-pin cable I/O ports for A-82X series , PCI-1800 series.
(16 channel single-ended or 8 channel differential)
- Blank pads for break detection , low-pass filter , current shut and voltage attenuation.
- On board cold junction circuit in analog input channel 1 (jumper selectable single-ended , differential mode)

Dimensions :114mmX170mm

Order Information

DB-8225/1 Screw Terminal Board With 37-Pin D-sub Cable 1m (CA-3710)

DB-8225/2 Screw Terminal Board With 37-Pin D-sub Cable 2m(CA-3720)

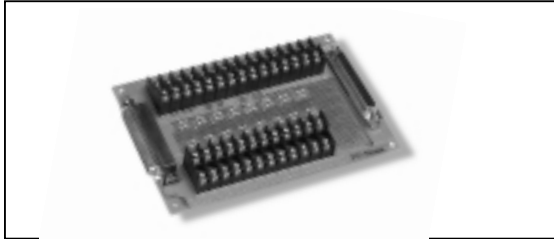

DB-1825 Screw Terminal Board

- Screw terminal board using 37-pin cable I/O ports for PCI-1802 series, PCI-1002, PCI-1202, ISO-AD32 series.

- (32 channel single-ended , 16 channel differential)
- Blank pads for break detection , low-pass filter , current shut and voltage attenuation.

Dimensions :114mm X 170mm

Order Information

(DB-1825/1 Screw Terminal Board With 37-Pin D-sub Cable 1m (CA-3710)

(DB-1825 /2 Screw Terminal Board With 37-Pin D-sub Cable 2m(CA-3720)

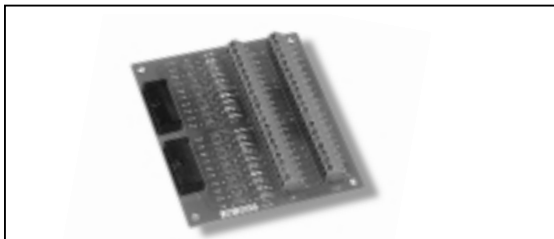

DB-8025 Screw Terminal Board

- DB-8025 is equipped with two 20-pin flat-cable connector.

- Compatible to 780 series daughter board
- Dimensions: 102mm x 114mm

Order information:

DB-8025: Screw Terminal Board

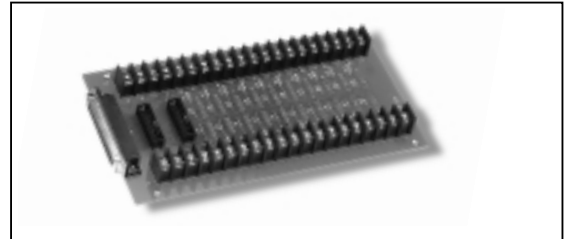

DB-8125 Screw Terminal Board

- DB-8125 is equipped with a DB-37 connector and two 20-pin flat-cable connectors
- Compatible to 880 series daughter board
- Dimensions : 221mm X 115mm

Order Information

DB-8125 Screw Terminal Board

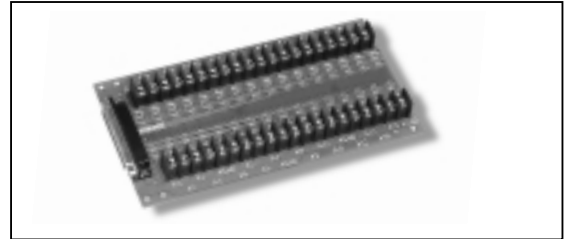

DB-8325 Screw Terminal Board

Screw terminal board using 37-pin cable for ISO-813 or other 813 series boards

- Dimensions : 220 mm X 114 mm

Order Information

DB-8325 Screw Terminal Board



DB-37 Direct Connection Board

- 37-pin D-sub connector pin to pin screw terminal for any 37 pin D-sub connector of I/O board
- Dimensions : 130 mm X 78 mm

Order Information

DB-37 Direct Connection Board



DN-PR4

4-Channel DIN-Rail Mounting Power Relay Module



Functional Description

The DN-PR4 Features a DIN-Rail mount and four form C electromechanical power relays for efficient switching of load by programmed control . The contact of each relay can control a 5 A load at 250VAC / 30VDC . The relay is energized by applying a +24V voltage signal to the appropriate relay channel . Each output is equipped with a LED to display their status. Each output is equipped with a varistor that shunts the surge voltage of the inductive load or electromagnetic brake to protect the relay contact point. All relay control and relay outputs are accessible through the wiring terminals.

Features

- 4 Form C Relays (SPDT)
- Industrial wiring terminals for easy output wiring
- Switch up to 5A at 250 VAC / 5A at 30VDC
- LEDs indicated relay status
- Build-in diodes to protect from wrong connection of external power supply.
- Designed Varistor to protect each channel's high voltage spike
- DIN-Rail mounting
- Connects directly to ICP CON I-7000 modules, ISO -730 isolated output , ISO-C64 output, ISO-P32C32 isolated output...etc.

Applications

- On/off control
- Energy management
- Test Automation
- Process Control

Specifications

- Channels : 4
- Relay type : SPDT (FORM C)
- RELAY
 - Nominal load : 5 A /250 VAC , 5A /30 VDC
 - Max. Switching power : 0.1HP
 - Max. Switching Voltage : 270VAC,150VDC
 - Max. Switching Current : 5A
 - Life Expectancy : Mechanical (2×10^7) , Electrical (3×10^4)
 - Time Value : Operate (10 ms)
 - Control Logic : Input +24V , relay off
- Power requirements : 24Vdc
- Power consumption : 2.2W
- Dimensions : 77mm (L) x 101mm (W) x 46 mm(H)
- Operating Temperature : 0 -60°C
- Storage Temperature : -20-70°C
- Humidity : 5% to 90 %; noncondensing

Varistor

- Maximun applied voltage : 300Vrms
- Clamping voltage: 760 V(10A)
- Varistor voltage: 470 V(current =1mA)
- Max. peak current : 1200A for 8 msec.

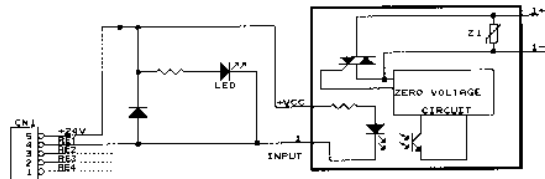

Order Description

- DN-PR4 : 4-channel DIN-Rail Mounting Power relay Module

Options

- ACE-540A: 24V/2A output power supply 85v-264VAC input range



DN-SSR4

4-Channel DIN-Rail Mounting Solid State Relay Module

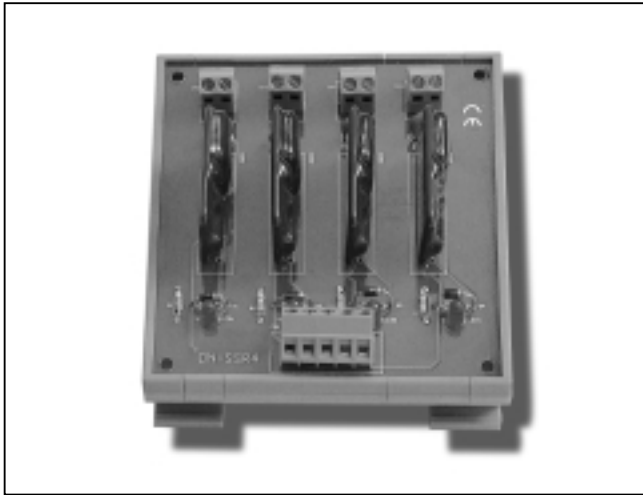

Functional Description

The DN-SSR4 includes 4 normally open, Form A, solid-state relays. The user can use the DN-SSR4 to switch high voltage load, up to 240VAC and up to 4 A. Four enunicator LEDs, one for each relay, light when their associated relay is activated. Each output equipped with a varistor that shunts the surge voltage of the inductive load or electromagnetic brake to protect the relay contact point. All relay control and relay outputs are accessible through the wiring terminals.

Features

- 4 optically isolated digital output channels
- 4 Form A solid-state relays
- Switch up to 4A at 240VAC
- 24VDC levels
- 2,500V optical isolation
- LEDs indicate relay status
- Screw terminal for easy field wiring
- Build-in diodes to protect from wrong connection of external power supply.
- Connects directly to ICP CON I-7000 modules, or ISO-730 isolated output board, ISO-C64 output board, ISO-P32C32 ...etc.
- DIN-Rail mounting

Applications

- On/off control
- Energy management
- Test Automation
- Process Control

Specifications

- Solid State Relay
- Load Voltage : 50-250VAC
- Repetitive peak OFF voltage : 600 V
- Surge current : 50 A
- Maxi. Load current : 4 A
- Maxi. "OFF-state" leakage current : 50 mA
- Operate time, max. : 1/2 cycle of voltage sine wave
- 1 ms (Zero-cross)

- Control Logic : Input +24V, relay off
- Power Consumption : external +24V @ 100 mA max.
- Dimension : 77 mm(L) x 101mm(W) x 66mm(H)
- Operating Temperature : 0 -60°C
- Storage Temperature : -20-70°C
- Humidity : 5% to 90 % noncondensing

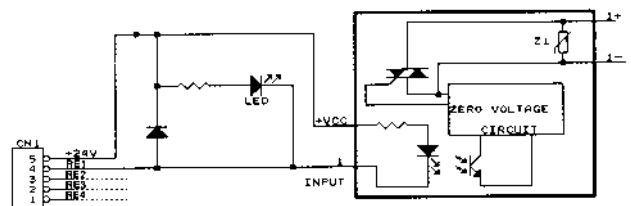

Order Description

- DN-SSR4: 4 channel DIN-Rail Mounting Solid State Relay Module

Options

- ACE-540A: 24V/2A output power supply 85V-264VAC input range.



RM Series DIN-RAIL Mounting Power Relay Modules I-950-ENC IP66 Industrial Enclosure

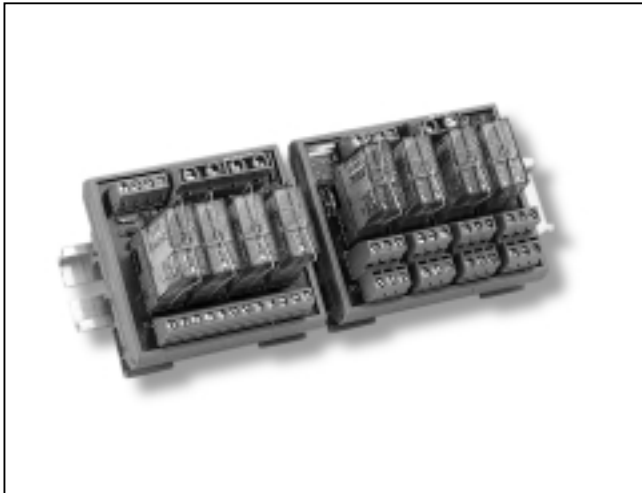

Functional Description

RM series relay modules are designed to be mounted on DIN RAIL TS-15, TS-32 or TS-35. RM-10X contains 1 form C relays, while RM-20X contains 2 form C relays. In order to prevent improper operation, reverse polarity protection is provided. A LED indicate the status of each channel. Those modules provide 4 channel relays, 8 channel relays and 16 channel relays version.

RM-10x series

Specifications

- Rated current for each relay : 16A
- Provide one N.C. and one N.O. for each channel
- Maxi. Peak current : 30A
- Maxi. Switching voltage : 400V AC
- Standard contact material : Ag Cd0
- Input Voltage : DC 24 V

RM-20x series

Specifications

- Rated current for each relay : 5A
- Provide two N.C. and two N.O. for each channel
- Maxi. Peak current : 10A
- Maxi. Switching voltage : 400V AC
- Standard contact material : Ag Nt
- Input Voltage : DC 24 V

Order Information

- RM-104: 4 channels power relay modules
- RM-108: 8 channels power relay modules
- RM-116: 16 channels power relay modules
- RM-204: 4 channels power relay modules
- RM-208: 8 channels power relay modules
- RM-216: 16 channels power relay modules

Introduction:

The I-950-ENC IP66 industrial enclosure is designed for use in industrial environments. It provides space for one or two I-7000 modules. It's rugged housing protect modules from Moisture , UV radiation ... etc.

Features

- Built-in DIN-RAIL for easy mounting
- Sidewall knockouts offer easy wire positioning
- Seal design provides anti-leak protection
- Dimension : 247 mm (width) x 180 mm (length) x 90mm (height)

Order Information

- I-950: IP66 Industrial Enclosure
- Includes
- Case
- Accessory
- 2 x Polyamide cable glands
- 4 x captive lid screws
- 1 x DIN-rail (21cm)

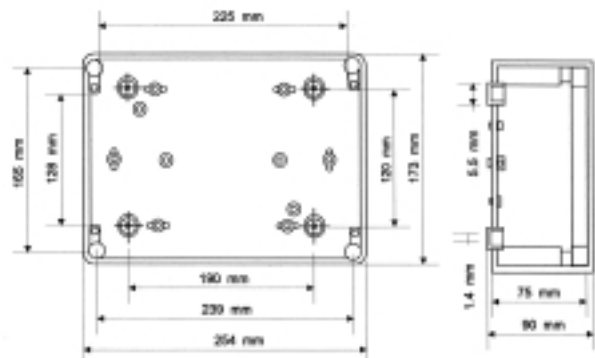



Cable & Accessories

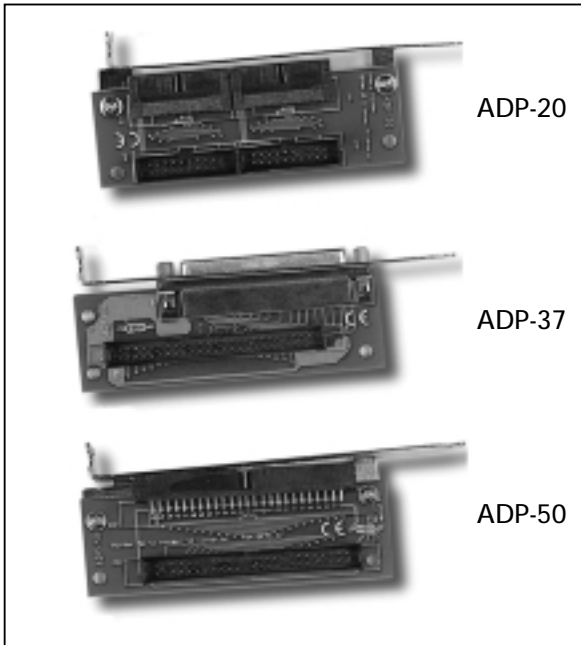

ADP-20

ADP-37

ADP-50

Introduction

Industrial I/O board normally requires cable and accessories to complete a package. Please refer to the following items.

Adapter Ordering Information

- ADP-20 : Extender, extends dual 20-pin flat-cable connectors to PC slot window, for AT bus I/O board.
- ADP-20/PCI : Extender, extends dual 20-pin flat cable connectors to pc slot window, for PCI bus I/O board
- ADP-37 : Adapter, 50-pin opto-22 ports to DB-37, for AT bus I/O board
- ADP-37/PCI : Adapter, 50-pin opto-22 ports to DB-37, for PCI bus I/O board
- ADP-50 : Extender, extends 50-pin flat-cable connectors to PC slot window, for AT bus I/O board.
- ADP-50/PCI : Extender, extends 50-pin flat-cable connectors to PC slot window, for PCI bus I/O board

Daughter Board

<p>(1) CA-0910</p> <p>• Cable for I-7188 and SST-900</p>	<p>(2) CA-0915</p> <p>• 9-pin Male-Female D-Sub Cable, 1.5m</p>	<p>(3) CA-0920</p> <p>• 9-pin Male-Male D-Sub Cable, 2m</p>	<p>(4) CA-9-2502</p> <p>• 9-pin Male & 25-pin Female D-Sub Cable, 20cm</p>	<p>(5) CA-2010</p> <p>• 20-pin flat cable, 1m</p>
<p>(6) CA-2020</p> <p>• 20-pin flat cable, 2m</p>	<p>(7) CA-2520</p> <p>• 25-pin Male-Male D-Sub flat Cable, 2m</p>	<p>(8) CA-3710</p> <p>• DB-37 Male-Male D-Sub Cable 1m</p>	<p>(9) CA-3720</p> <p>• DB-37 Male-Male D-Sub Cable 2m</p>	<p>(10) CA-5015</p> <p>• 50-pin flat cable 1.5m</p>
<p>(11) CA-5002</p> <p>• 50-pin flat cable 20cm</p>	<p>(12) CA-4002</p> <p>• 37-pin Male D-Sub connector with plastic cover</p>	<p>(13) CA-40-37</p> <p>• 40-pin flat & D-Sub 37-pin Female Cable 20cm</p>	<p>(14) CA-GPI10, 20, 40</p> <p>• GPIB cable 1, 2, 4 meter long</p>	<p>(15) CA-2002</p> <p>• 20-pin flat cable 20cm x 2</p>



Cable & Accessories

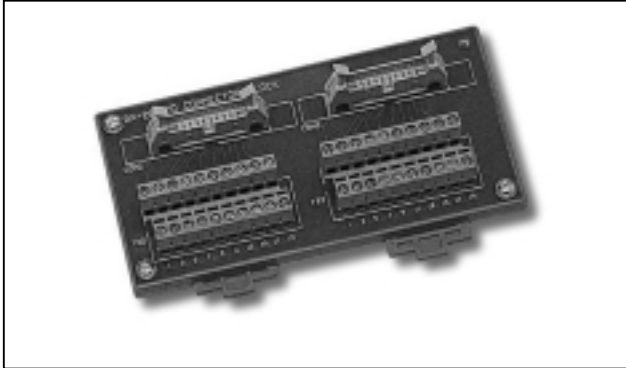

DN-20

I/O Connector Block with DIN-Rail Mounting

- Two 20-pin header
- Pin to Pin screw terminal for I/O connected

Ordering Information

- DN-20/1m: Terminal Board with two 20-Pin flat-cable 1m(CA-2010)
- DN-20/2m: Terminal Board with two 20-Pin flat-cable 2m(CA-2020)



DN-25

I/O connector Block with DIN Rail Mounting

- One 9-pin D-sub connector
- One 25-pin D-sub connector
- Pin to Pin screw terminal for I/O connected

Ordering Information

- DN-25: Terminal Board With One 9 Pin D-sub cable(CA-0920) and One 25 pin D-sub cable(CA-2520)

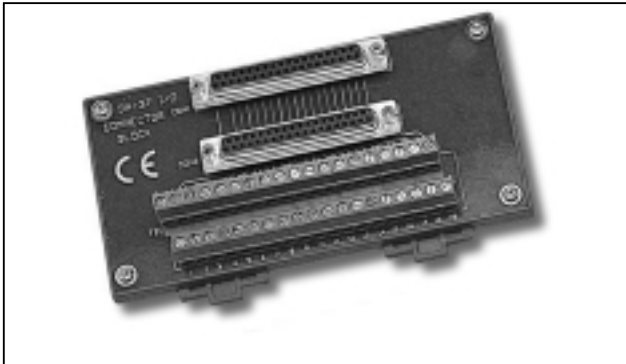

DN-37 :

I/O Connector Block with DIN-Rail Mounting

- Two 37-pin D-sub connector (One for expansion)
- Pin to Pin screw terminal for I/O connected

Ordering Information

- DN-37: Terminal Board With One 37 -Pin D-sub Cable 1m(CA3710)
- DN-37: Terminal Board With One 37-Pin D-sub Cable 2m(CA-3720)

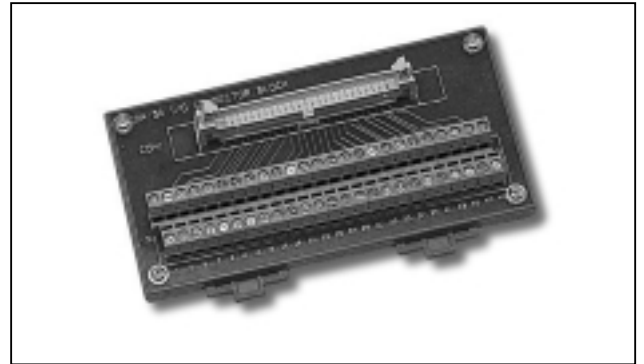

DN-50

I/o Connector Block with DIN-Rail Mounting

- One 50 pin header
- Pin to Pin screw terminal for I/O connected

Ordering Information

- DN-50: Terminal Board with One 50 pin flat-Cable 1.5m(CA-5015)
- DIN-Rail Mounting Terminal Board Dimensions

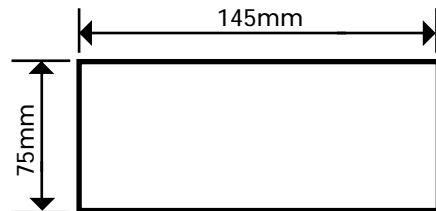

DN-20, DN-25, DN-37, DN-50 Terminal Board

Daughter Board