

QUINT4-PS/1AC/48DC/10 Single-Phase DIN Rail Power Supply

 [perle.com/products/industrial-power-supply/quint-ps-1ac-48dc-10-29046118.shtml](https://www.perle.com/products/industrial-power-supply/quint-ps-1ac-48dc-10-29046118.shtml)

48V Industrial Power Supply for Regulated AC/DC or DC/DC Conversion

- 48 V DC Output Voltage
- Adjustable Output Voltage Ranges: 48 to 56 V DC
- 10 Amps
- 480 Watts
- Single phase AC or DC Input
- Input Voltage Range: 85 ... 264 V AC and 90 ... 350 V DC



The **QUINT4-PS/1AC/48DC/10 Industrial Power Supply** is rugged AC to DC and DC to DC Converter built to meet the high stability and efficiency expectations of industrial, machine automation and process control environments. It also features the unique combination of preventive function monitoring and power reserve in an incredibly compact size. This Switching (switch mode) Power Supply ensures a regulated output voltage even in the event of voltage fluctuations in the power supply network. During parallel operation, and when connected to different phases, loads are reliably supplied even in the event of problems with the input voltage. With all required safety certifications to support ITE (Information Technology Equipment), ruggedized packaging, extended operating temperatures, high peak load capabilities and high isolation voltages, this QUINT Industrial Power Supply is designed to meet the need of your industrial application.

POWER BOOST: reliably start difficult loads

A high degree of flexibility is required to configure, optimize and expand large systems. To optimally adapt a system or machine to your requirements, a power reserve in the power supply unit is crucial. The QUINT4-PS/1AC/48DC/10 supplies up to 50% additional current without a voltage drop. This is useful when it is not possible to predict which loads will be switched on at the same time or high switch-on currents of

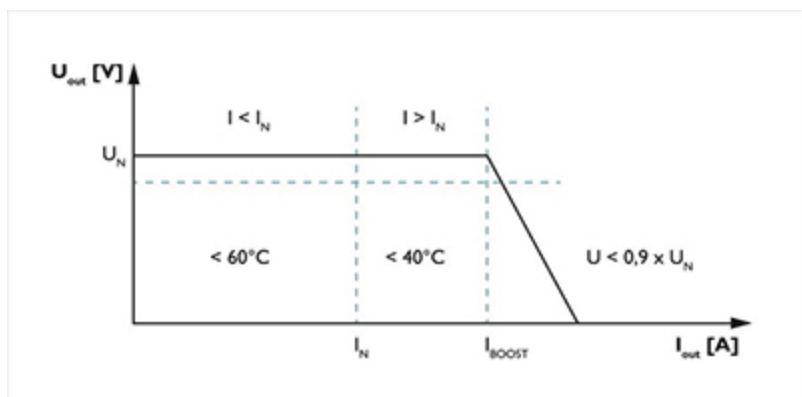

capacitive loads have to be absorbed without voltage dips. With the QUINT Power Boost function a static boost will continuously provide up to 125% of the nominal current. In addition, you can use the dynamic boost to supply 200% of the nominal current for 5 seconds when starting up heavy loads.

Preventive function monitoring reports critical operating states before they occur

With the QUINT4-PS/1AC/48DC/10 Industrial Power Supply, the output voltage and output current are constantly monitored. Preventive function monitoring visualizes critical operating states and indicates them locally and remotely to the controller as follows:

- Via LED
- Via floating relay contact
- Via active switching output

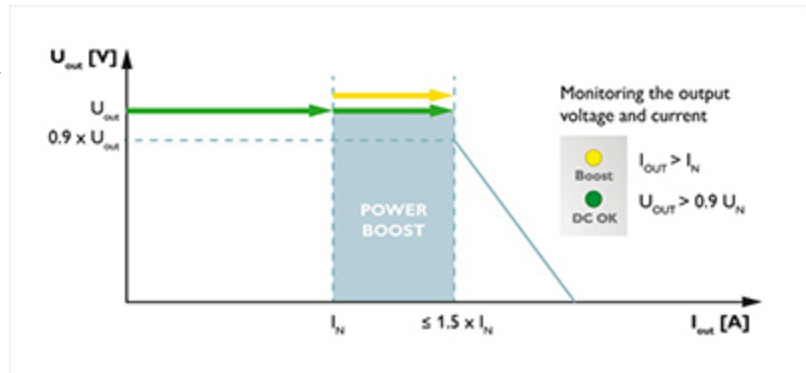

High efficiency and low no load power consumption

Compared with other products on the market, this QUINT Industrial Power Supply provides excellent energy savings. With a very low no load power consumption and high efficiency at nominal load, just a small amount of electrical energy is converted into undesired heat energy making these very ECO friendly power supplies.

SFB (Selective Fuse Breaking) Technology

SFB Technology can be used to quickly and reliably trip miniature circuit breakers and fuses connected on the secondary side. In the event of a short circuit on the secondary side, this QUINT supply up to 6 times the nominal current for 15 ms. Faulty current paths are switched off selectively, the fault is located, and important system parts remain in operation. Loads that are connected in parallel are still supplied with energy ensuring continued operation of these system parts.

- Tripping circuit breakers: The circuit breaker is typically tripped by the high SFB current within 3 to 5 ms. As a result, any voltage dips for loads connected in parallel are avoided.
- Tripping a fuse: Fuses are tripped by melting the predetermined breaking point inside the fuse capsule. The tripping characteristic of the fuse is described by the melting integral (I^2t). A high current is crucial in order to achieve a very short tripping time.



Near Field Communication (NFC)

Near Field Communication (NFC) is a transmission standard for wireless and contactless data exchange at a close distance. With NFC, you can easily parameterize the QUINT4-PS/1AC/48DC/10 Power Supply settings such as define signaling thresholds for preventive function monitoring, adjust output voltage, and

terminal device. You can also save and send configuration profiles on your mobile terminal device. QUINT4-PS/1AC/48DC/10 Power NFC App on the Google Play Store

Ideal application environments for the QUINT4-PS/1AC/48DC/10 DIN Rail Power Supply

- Shipbuilding
- machine building
- automated production process
- industrial control, automation, assembly, and test equipment
- building control, security and surveillance, and climate control systems.
- power countless industrial automation devices such as sensors, controllers and valves



Other reasons to choose the QUINT4-PS/1AC/48DC/10 Industrial Power Supply

- Shipbuilding Approvals
- Adjustable Output Voltage Ranges: the output voltage can be optimally adjusted to meet specific application environment requirements, such as compensating for a voltage drop caused by a long cable length.
- Robust input side: high noise immunity, integrated gas-filled surge arrester (up to 6 kV), and ≥ 20 ms mains failure buffer time
- Configurable signaling of DC OK or selectable power thresholds
- Space savings in the control box, thanks to a narrow, slim-line design
- Voltage Isolation input/output: 4 kV AC
- Protections: Short-circuit, Overload, Over voltage, Over-temperature
- To ensure maximum availability all models have high MTBF (Mean Time Between Failure) values.

Environmental Product Compliance

REACH SVHC	Lead 7439-92-1
------------	----------------

China RoHS	Environmentally Friendly Use Period = 25;
------------	---

General

Net weight	1.3 kg
------------	--------

Efficiency	typ. 94 % (120 V AC)
	typ. 95 % (230 V AC)

Insulation voltage input/output	4 kV AC (type test)
	2 kV AC (routine test)

Insulation voltage input / PE	3.5 kV AC (type test)
-------------------------------	-----------------------

Insulation voltage output / PE	0.5 kV DC (type test)
	0.5 kV DC (routine test)
Protection class	I
Degree of protection	IP20
MTBF (IEC 61709, SN 29500)	> 1100000 h (25 °C)
	> 676000 h (40 °C)
	> 317000 h (60 °C)
Mounting position	horizontal DIN rail NS 35, EN 60715
Assembly instructions	alignable: $P_N \geq 50\%$, 5 mm horizontally, 15 mm next to active components, 50 mm vertically alignable: $P_N < 50\%$, 0 mm horizontally, 40 mm vertically top, 20 mm vertically bottom
Standards and Regulations	
Electromagnetic compatibility	Conformance with EMC Directive 2014/30/EU
Noise emission	Additional basic standard EN 61000-6-5 (immunity in power station), IEC/EN 61850-3 (energy supply)
Noise immunity	Immunity according to EN 61000-6-1 (residential), EN 61000-6-2 (industrial), and EN 61000-6-5 (power station equipment zone), IEC/EN 61850-3 (energy supply)
Standards/regulations	EN 61000-4-2
Contact discharge	4 kV (Test Level 2)
Standards/regulations	EN 61000-4-3
Frequency range	80 MHz ... 1 GHz
Test field strength	10 V/m (Test Level 3)
Frequency range	1.4 GHz ... 2 GHz
Test field strength	3 V/m (Test Level 2)
Standards/regulations	EN 61000-4-4
Comments	Criterion B
Standards/regulations	EN 61000-4-6
Frequency range	0.15 MHz ... 80 MHz
Voltage	10 V (Test Level 3)
Conducted noise emission	EN 55016 EN 61000 6-4 (Class A)

Standards/regulations	EN 61000-4-8
	EN 61000-4-11
	EN 61000-4-9
	EN 61000-4-12
	EN 61000-4-16
	EN 61000-4-18
Low Voltage Directive	Conformance with Low Voltage Directive 2014/35/EC
Standard - Safety of transformers	EN 61558-2-16 (air clearances and creepage distances only)
Standard - Electrical safety	IEC 60950-1/VDE 0805 (SELV)
Standard – Electronic equipment for use in electrical power installations and their assembly into electrical power installations	EN 50178/VDE 0160 (PELV)
Standard – Safety extra-low voltage	IEC 60950-1 (SELV)
	EN 60204-1 (PELV)
Standard - Safe isolation	DIN VDE 0100-410
Standard – Limitation of mains harmonic currents	EN 61000-3-2
Shipbuilding approval	DNV GL, PRS, BV, LR, ABS
UL approvals	UL Listed UL 508
	UL/C-UL Recognized UL 60950-1
	UL ANSI/ISA-12.12.01 Class I, Division 2, Groups A, B, C, D (Hazardous Location)
Shock	18 ms, 30g, in each space direction (according to IEC 60068-2-27)
Vibration (operation)	5 Hz ... 100 Hz resonance search 2.3g, 90 min., resonance frequency 2.3g, 90 min. (according to DNV GL Class C)
Approval - requirement of the semiconductor industry with regard to mains voltage dips	SEMI F47-0706; EN 61000-4-11
Rail applications	EN 50121-3-2
Overvoltage category (EN 60950-1)	II (≤ 5000 m)
Overvoltage category (EN 61010-1)	II (≤ 5000 m)
Overvoltage category (EN 62477-1)	III (≤ 2000 m)

Connection method	Screw connection
Conductor cross section solid min.	0.2 mm ²
Conductor cross section solid max.	6 mm ²
Conductor cross section flexible min.	0.2 mm ²
Conductor cross section flexible max.	4 mm ²
Conductor cross section AWG min.	30
Conductor cross section AWG max.	10
Stripping length	6.5 mm
Output data	
Nominal output voltage	48 V DC
Setting range of the output voltage (U _{Set})	48 V DC ... 56 V DC (constant capacity)
Nominal output current (I _N)	10 A
Static Boost (I _{Stat.Boost})	12.5 A
Dynamic Boost (I _{Dyn.Boost})	15 A (5 s)
Selective Fuse Breaking (I _{SFB})	60 A (15 ms)
Derating	> 60 °C (2.5%/K)
Connection in parallel	Yes, for redundancy and increased capacity
Connection in series	yes
Feedback resistance	≤ 60 V DC
Protection against surge voltage on the output	≤ 60 V DC
Control deviation	< 0.5 % (Static load change 10 % ... 90 %)
	< 2 % (Dynamic load change 10 % ... 90 %, (10 Hz))
	< 0.25 % (change in input voltage ±10 %)
Residual ripple	< 70 mV _{PP} (with nominal values)
Output power	480 W
Typical response time	300 ms (from SLEEP MODE)
Maximum power dissipation in no-load condition	< 5 W (120 V AC)

< 5 W (230 V AC)

< 28 W (230 V AC)

Connection data for signaling

Connection method Push-in connection

Conductor cross section solid min. 0.2 mm²Conductor cross section solid max. 1.5 mm²Conductor cross section flexible min. 0.2 mm²Conductor cross section flexible max. 1.5 mm²

Conductor cross section AWG min. 24

Conductor cross section AWG max. 16

Stripping length 8 mm

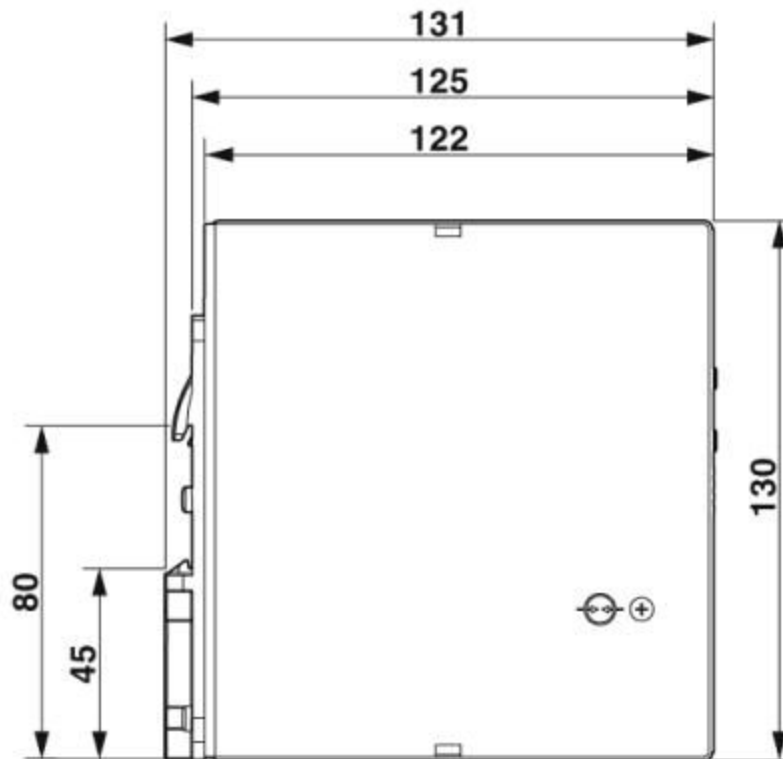
Dimensions

Width 70 mm

Height 130 mm

Depth 125 mm

Width with alternative assembly 122 mm

Height with alternative assembly 130 mm

Depth with alternative assembly	73 mm
Weight per piece	1617.0 GRM
Input data	
Nominal input voltage range	100 V AC ... 240 V AC
	110 V DC ... 250 V DC
Input voltage range	100 V AC ... 240 V AC -15 % ... +10 %
	110 V DC ... 250 V DC -18 % ... +40 %
Dielectric strength maximum	300 V AC 60 s
AC frequency range	50 Hz ... 60 Hz -10 % ... +10 %
Discharge current to PE	< 3.5 mA
Current consumption	6.8 A (100 V AC)
	5.5 A (120 V AC)
	2.8 A (230 V AC)
	2.7 A (240 V AC)
Nominal power consumption	519 VA
Inrush surge current	typ. 11 A (at 25 °C)
Mains buffering	typ. 32 ms (120 V AC)
	typ. 32 ms (230 V AC)
Input fuse	12 A (slow-blow, internal)
Choice of suitable circuit breakers	10 A ... 16 A (Characteristic B, C, D, K or comparable)
Type of protection	Transient surge protection
Protective circuit/component	Varistor, gas-filled surge arrester
Connection data, onput	
Connection method	Screw connection
Conductor cross section solid min.	0.2 mm ²
Conductor cross section solid max.	6 mm ²
Conductor cross section flexible min.	0.2 mm ²
Conductor cross section flexible max.	4 mm ²
Conductor cross section AWG min.	30

Conductor cross section AWG max.	10
Stripping length	6.5 mm
Ambient conditions	
Degree of protection	IP20
Ambient temperature (operation)	-25 °C ... 70 °C (> 60 °C Derating: 2.5 %/K)
Ambient temperature (start-up type tested)	-40 °C
Ambient temperature (storage/transport)	-40 °C ... 85 °C
Max. permissible relative humidity (operation)	≤ 95 % (at 25 °C, non-condensing)
Climatic class	3K3 (in acc. with EN 60721)
Degree of pollution	2
Installation height	≤ 5000 m (> 2000 m, observe derating)

Approvals

- ABS
- cULus Listed
- BV
- DNV GL
- cULus Recognized
- EAC
- UL Recognized
- cUL Recognized
- cUL Listed
- LR
- UL Listed

QUINT-1-Phase Industrial Power Supply Block Diagram

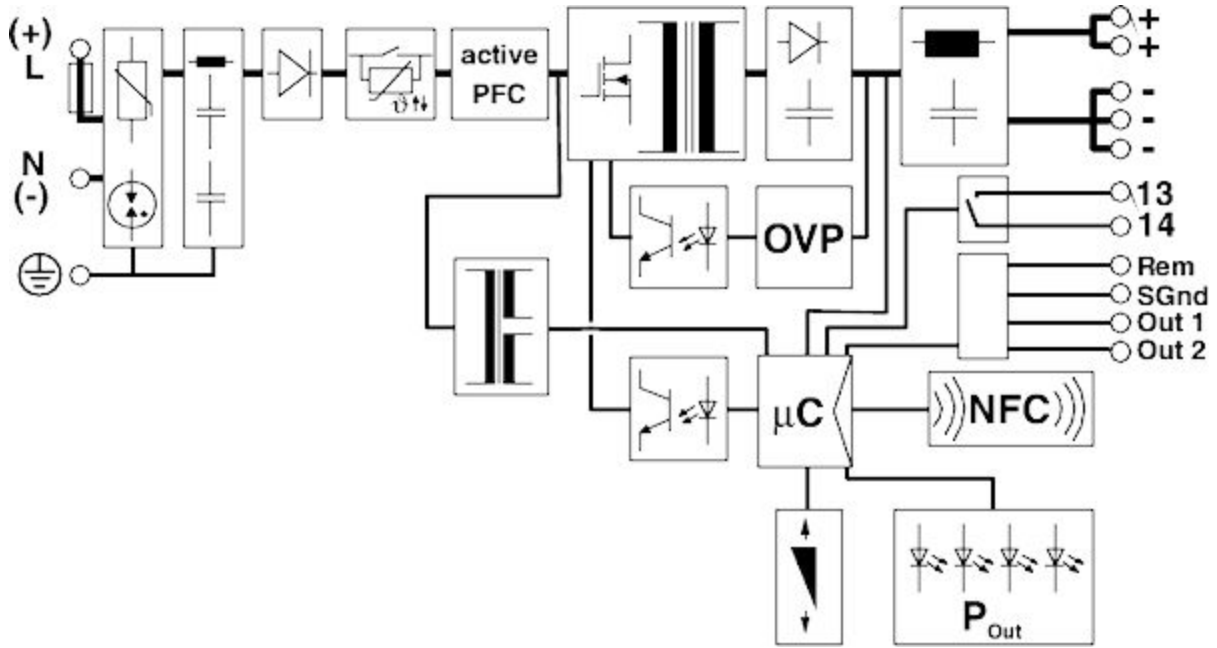

Schematic diagram

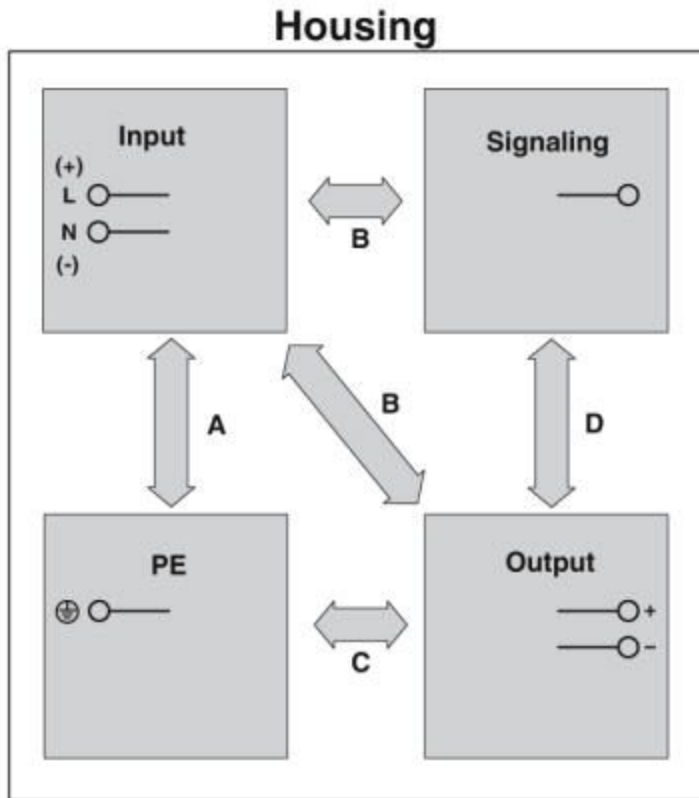

Input current vs output current

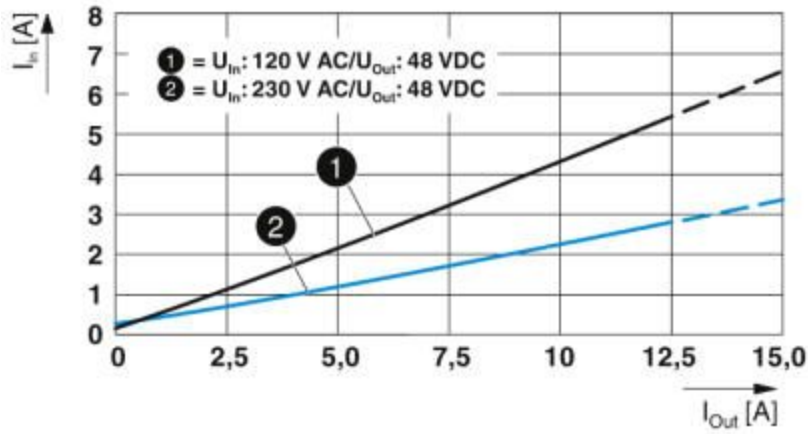

Power factor diagram

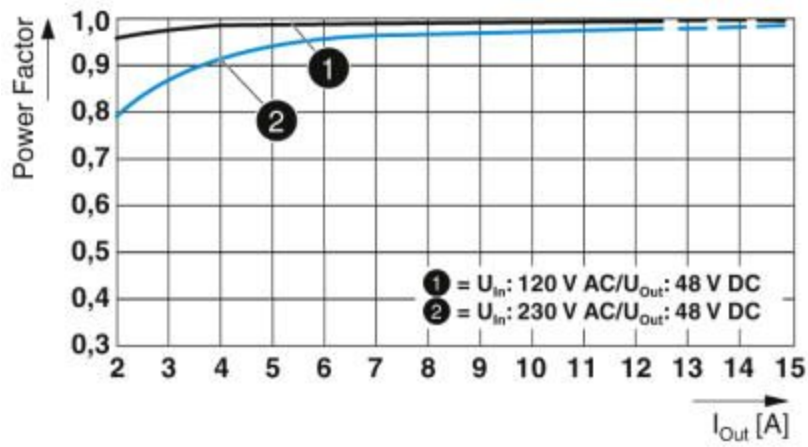

Efficiency diagram

